

Investigation of damage on wall panels due to blast vibration

1) S.A.N.S.Wickramasinghe, 2) S.R.Masakorala, 3) E.A.T.P.Jayasinghe, 4) G.H.M.J.Subashi De Silva, 5)G.S.Y.De Silva

Department of Civil and Environmental Engineering

e-mail: 1) achala.wickramasinghe@gmail.com

2) rajamalimasakorala@gmail.com

3) jayasinghepiumal@gmail.com

4) subashi@cee.ruh.ac.lk

5) sudhira@cee.ruh.ac.lk

Abstract

As the energy left over from a blast vibration process transmits to the surrounding, waves displace particles in their paths giving rise to particle velocities. However, the damage occurs which depends on the received structural vibration, may vary according to the soil type, soil structure interaction and characteristics of a structure. In Sri Lanka, various threshold values of blast vibration are being used although still many complains are raised on damages to structures due to blasting activities. It is necessary to understand whether all of the cracks have been induced due to the blasting activity as in some situations, the blast vibration test results were within the allowable limits.

This paper presents a study on investigating the damage on wall panels due to blast vibration. Location for the construction of the experimental model structure was selected from the initial site investigation and the vibration level measurements at different locations. The initial test carried out has shown that the soil structure interaction should be strong enough to obtain the ground vibrations. A wall panel, size of 1200 mm×1000 mm with free ends, was constructed closer to a rock blasting quarry and the effect of vibration on the structure was monitored. A significant crack was observed at the foundation level of the wall panel at a vibration level around 30mms-1 of ppv. Along with the experimental method, numerical modeling was carried out with the Finite Element Modeling using SAP 2000 software. Results of the numerical study also verify that the tensile stresses of the bottom level of the wall panel exceed the splitting tensile strength.

Key words: Damage, Blast Vibration, Wall Panels

1. Introduction

Blasting is most commonly used for rock fragmentation in the construction industry. For these blasts, the industry use explosives such as ANFO (Ammonium Nitrate and Fuel Oil), dynamite, TNT etc. It is a process of detonating explosives charged into holes drilled in the rock.

The total amount of explosive energy is not used in during a blasting process. Part of the energy is wasted away in the form of ground vibrations, air over pressure and flyrock. Ground vibration is associated with many problems in human activities especially in residential area. Therefore, number of complains are raised from nearby residents about structural damages caused by the effects of blasting. The vibration effects vary from annoying people and disruption of some businesses to possible structural damage.

Therefore, it is expected that rock blasting in a project area for construction raises many public complaints or protests. For example, in Hambantota harbor project [1] and the Southern Transport Development Project [2] many complains have been raised on rock blasting activities. It should be noted that particularly at main quarry sites, test blasts are to be carried out in order to address the problems associated especially with the neighbors and accordingly appropriate measures need to be taken. Compensation packages need to be worked out to provide suitable solutions to the public concerns. However, the project proponent needs to be made to understand that it is not possible to address the public complaints on rock blasting issues only through one environmental assessment. Such assessments need to be made at regular intervals.

However, it is questionable whether all of the cracks and structural damages are induced due to the blasting activity because in some situations, the blast vibration test results are within the allowable limits.

Even though there are set out interim standards on vibration pollution and control that varies according to the type of structure [3], they may also vary according to factors as site conditions, soil type etc. Therefore, the need of a threshold, applicable to our conditions on which to base the blasting operations was identified. Then a structure could be assessed to check whether the level of vibration received at the structure is within the allowable limits.

Peak Particle Velocity (PPV) was used for the measurement of the received energy as it is closely related to the damage caused to different types of structures by wave propagation due to blasting. In previous studies, it has been found that the peak particle velocity would be the best measure of a blast vibration [e.g.4]. This seems appropriate because when blasting is carried out, energy left over from rock breaking processes by blasting, is transmitted to surrounding areas as elastic waves. As these waves travel, they displace particles in their paths giving rise to particle velocities.

In the present study, the damage on wall panels due to blast vibration was investigated. Considering the variety of soil-structure interaction and structure conditions, assessment of the damage in structures was done on the basis of measurement of vibrations received at the structure. Generated

ground vibration was measured simultaneously with structural response. Finite Element model analysis was done by modelling the experimental structure with the physical dimensions and the geometric and physical material properties of the structure. The model was subjected to vibration induced by blasting and the model's response was compared with the experimental findings.

2. Objectives

This research was mainly based on the following objectives.

- Carrying out the experimental study in order to identify the effect of blasting on the physical model structure.
- Numerical modelling with Finite Element Method to investigate the effect of blasting on the experimental model structure.

3. Methodology

To find out the behaviour of a wall panel due to blast vibration, following methodologies were used. They are,

- Experimental method
- FEM modelling

3.1. Experimental method

3.1.1. Preparation of experimental model

Initial site investigations were done and vibration levels were measured at different locations to select a location for the construction of the experimental model.

A four channel seismograph was used for the measurement of vibration level. A location was selected to cast the wall panel, where the highest value of vibration was observed in order to receive enough range of vibration for the experiment.

Table 1: PPV values at the initial site investigation

Position	Distance from the blasting point (m)	Depth of a blast hole (ft)	Observed maximum ppv (mm/s)
P1	4.1	7.5	23.8
P2	10.9	5	10.2

A brick wall panel having a size of 1200 mm × 1000 mm was cast at the selected quarry at Hapugala (Figures 1 and 2). The model brick wall panel was constructed using a rubble foundation and stretcher bond of 1:5cement: sand mortar. A 10 mm thick plaster with 1:1:9 lime:cement:sand was used. These variables were selected in order to be representative of the commonly maintained practices in Sri Lanka. A lime coat was painted on the dry plaster to create a clear surface on the wall panel. This was necessary for the clear observation of cracks propagation and any other possible damage to the experimental model structure.

After observing initial damage, the damage was repaired and restored for further investigations (Figure 3).

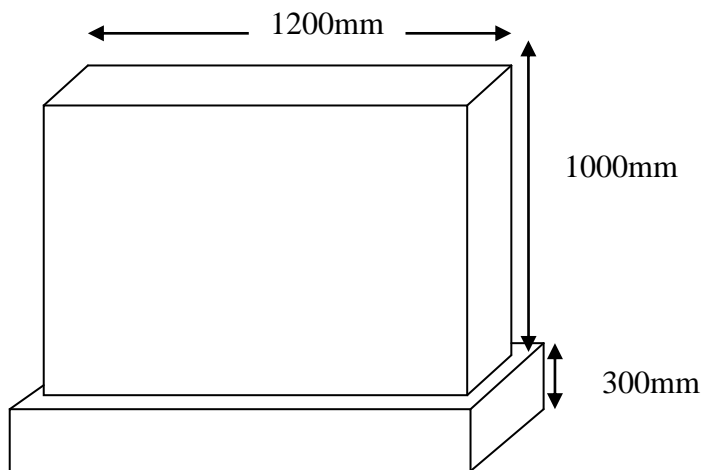

Figure 1: schematic diagram of cantilever wall



Figure 2: Constructed wall panel



Figure 3: After laying concrete at the joint

3.1.2. Vibration measurement

The seismograph (Blastmate III) was set up before starting the monitoring. A transducer was fixed on the surface soil using ground spikes, pointing the arrow located on the top of the standard transducer in the direction of the event. Transducer is capable in monitoring the ground vibrations in three directions: transverse, vertical, and longitudinal directions [5]. The standard transducer was checked to ensure that it was securely in place and level. Before measuring, it was programmed to record the vibration in continuous mode and fixed time stop mode. Both 'Geo' and 'Mic' trigger sources were selected with the trigger level set up to a high value as blasting produced a high vibration level. This was necessary to avoid recording unwanted minor vibration induced possibly by walking of experimenters. Particle velocity is commonly reported as millimetres per second, and frequency is commonly reported as cycles per second or Hertz (Hz). Recorded vibration was produced into an event report. The event report includes transverse, vertical and longitudinal vibrations and noise induced by the blasting.

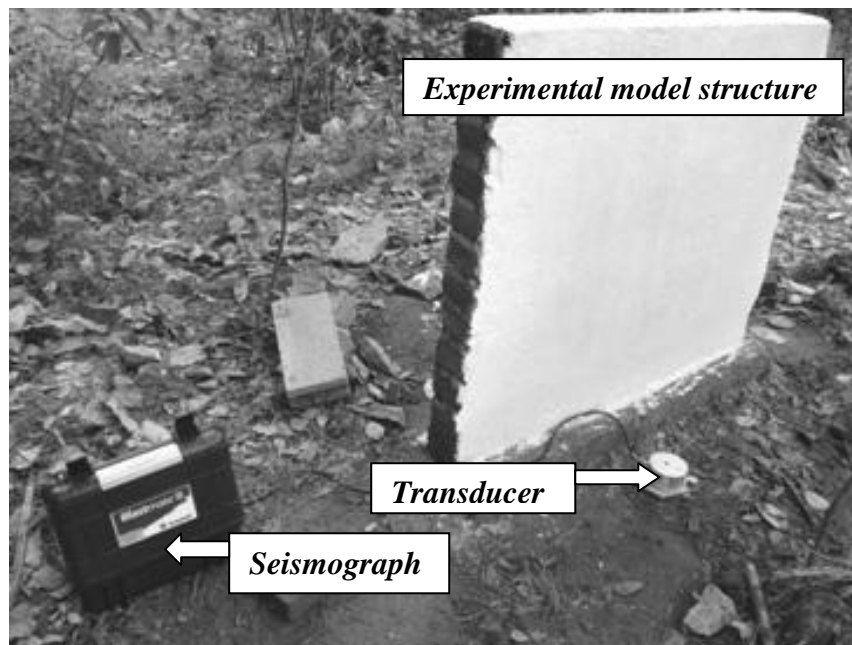

Figure 4: Measuring ground vibration with the

3.2. FEM modelling

3.2.1. Development of the model

The experimental model structure was idealized (Figure 5) and modelled in FEM using SAP 2000 software [6]. This model was used for both the static and dynamic analysis of the structure.

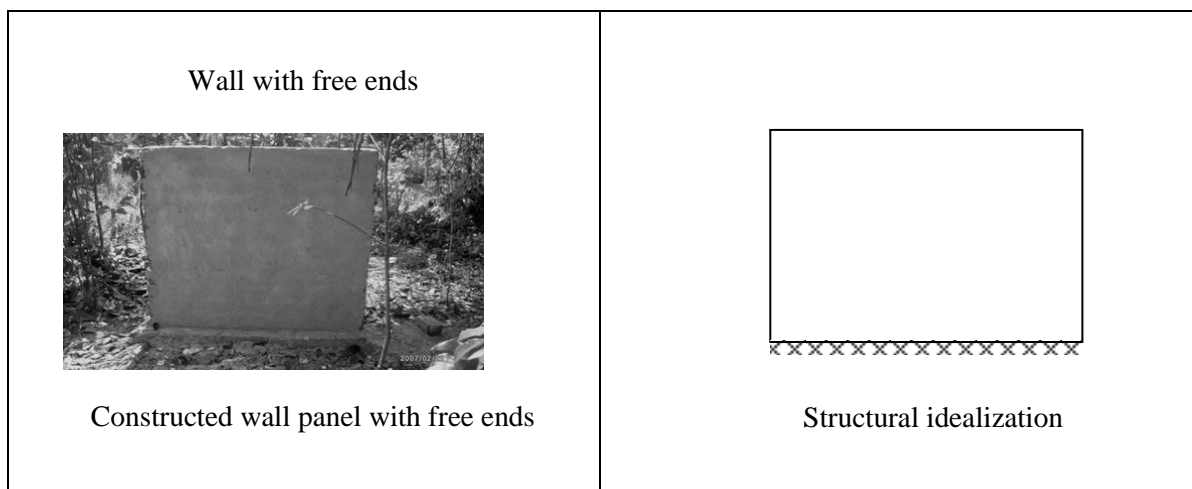

Figure 5: Idealization of the wall panel for FEM

Wall panels were modelled using shell elements of 100mm×100mm. The same dimensions as of the experimental model (i.e., 1200mm× 1000mm) were selected for the model and it was assumed that the plaster remains as a linear elastic material until cracking. The constructed wall panel under consideration and the structural idealization of it for the static and dynamic analysis is shown in Figure 5. Except the wall connection at the foundation, other supports were considered as free in the analysis. The bottom boundary was restrained in all six degrees of freedom.

A new material which closely represents the properties of 1:1:9 lime:cement:sand plaster was defined with a membrane and bending thickness of 10mm, according to the plaster thickness. Properties of this material are listed in Table 2.

Table 2: Properties of the new material

Property	Value
Mass per unit volume	$1.89 \times 10^{-12} \text{ kN/mm}^4 \text{ s}^2$
Weight per unit volume	$1.854 \times 10^{-8} \text{ kN/mm}^3$
Modulus of Elasticity	$2.27 \times 10^{-2} \text{ kN/mm}^2$
Poission's ratio	0.13
Co-efficient of thermal expansion	$1.1 \times 10^{-6}/\text{c}^0$

3.2.2. Model Analysis

The event report of a particular blasting event was obtained using the Blastware software. Among the three vibrations and noise level, vibration in longitudinal direction was selected as it was always dominant in affecting the structure (Figure 6).

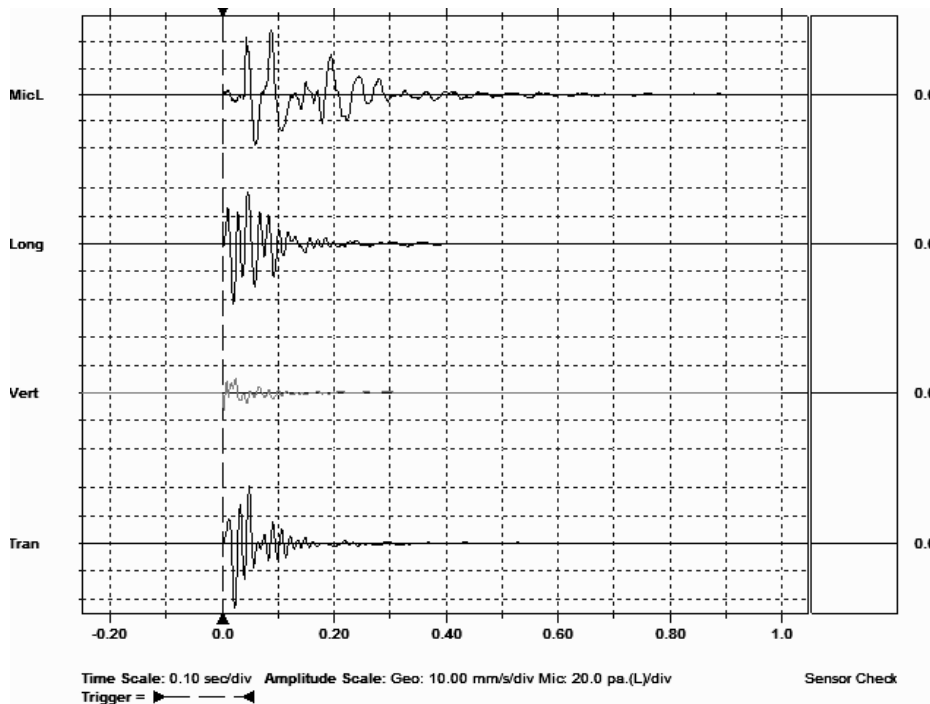

Figure 6: Vibration in three directions and noise level measured using the seismograph

The response spectrum of the event was obtained using ‘Piecewise exact method’ using MATLAB [7-9]. Then the available response spectrum of the SAP 2000 software was modified to be representative of the obtained graph.

In the analysis, response spectrum was input in the longitudinal direction (U2-y). A scale factor was selected to multiply the values of the input graph to reach the obtained graph using MATLAB. Then the response spectrum analysis was carried out for the model.

4. Results

4.1. Experimental measurements

Even though blasting activities were carried out, initially no damage was observed at the structure.

Table 3: Peak vector sum velocity induced by blasting

<i>Velocity (mm/s)</i>	<i>Remarks</i>
<i>0.49</i>	<i>Blasting of boulders</i>
<i>10.2</i>	<i>Blast hole depth of 7 feet</i>
<i>11</i>	<i>Blast hole depth of 5 feet</i>
<i>14.2</i>	<i>Blast hole depth of 8 feet</i>

Continuation of blasting was resulted in a significant crack between the wall and the foundation at a vibration level of 30.2 mm/s of ppv. Figure 7 shows the frequency spectrum of the vibration in three measured directions. Frequency spectrum shows that the most of the energy of the signal concentrated at a frequency of 50 Hz. After the joint was concreted and restored, significant crack (i.e., a structural separation) was formed at the top level of the concreted foundation.

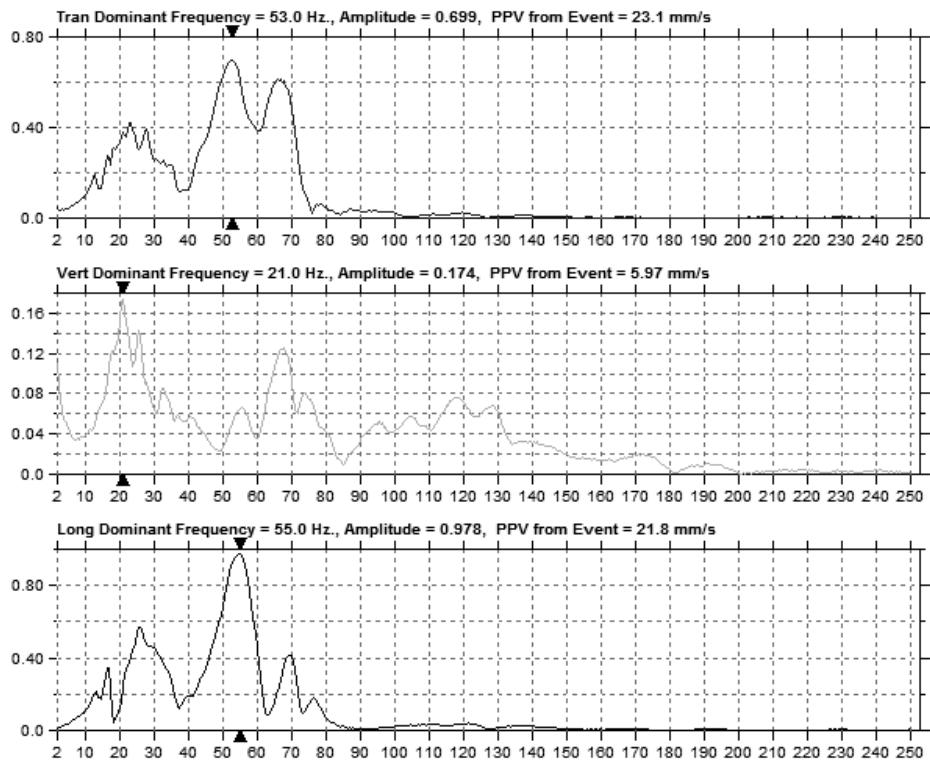

Figure 7: FFT report generated for the vibrations three

4.2. FEM modeling

The response spectrum obtained for the longitudinal vibration of the event of 30.2 mm/s ppv is shown in Figure 8.

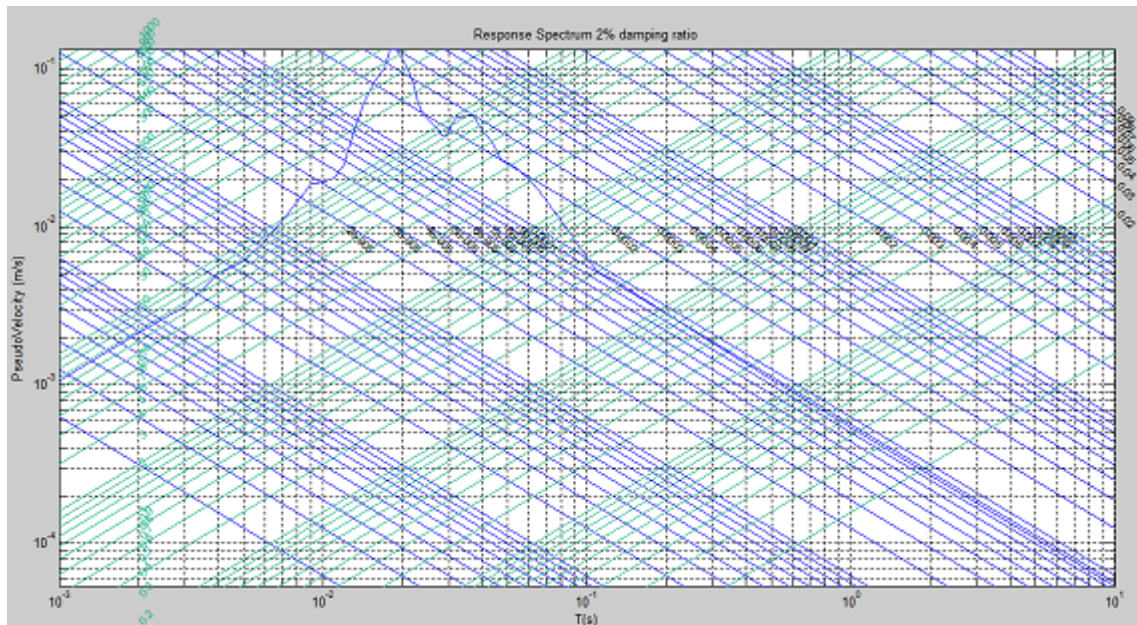

Figure 8: Response spectrum for longitudinal vibration of 30.2 mm/s ppv blasting event

Figure 9 shows the stress distribution along the structure when exposed to the response spectrum of dynamic force. The results of the numerical model using SAP 2000 highlighted an increased S22 stress concentration of about $420 \times 10^{-3} \text{ N/mm}^2$ at the bottom level of the structure.

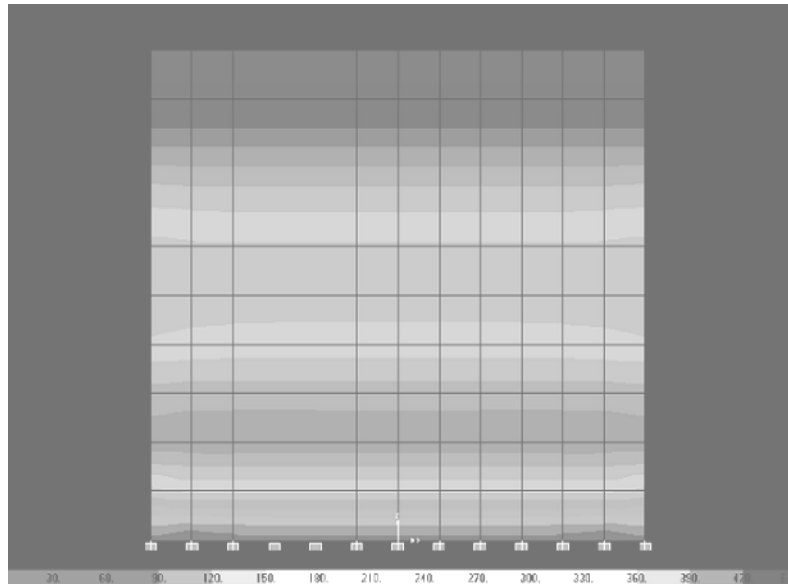

Figure 9: Stress distribution obtained from analysis

5. Discussion

According to the experimental study, the cantilever type wall panel experienced a structural separation from the foundation by a significant cracking at a ppv of 30.2 mm/s at 50 Hz of frequency. This vibration magnitude is similar to the magnitude reported in a previous study in which safety of low-rise residential structures from vibrations generated by mining blasting was investigated [4]. In their study, surface cracks were observed whereas in the current study, a significant crack at the bottom of the structure was observed. This different might be attributed to the low stiffness of the structure used in the current study: for a structure with low stiffness large effect due to the blasting activity can be expected. Another previous study has identified structural cracks even below 2mm/s ppv (frequency range of 10-50 Hz) in which the vibration considered was a continuous vibration over a long period of time and the wall panels were having openings [10]. As the effect of such a vibration last long period, it is comparable with the current study where a sudden large vibration over a short period of time was investigated.

From the numerical model, the increased stress concentration at the bottom level of the wall panel found from the FEM analysis also implies that there is a high possibility of damage at that level. An increased S22 stress concentration of about 0.42 N/mm^2 observed at the bottom level of the plaster was closer to the splitting tensile strength of 0.402 N/mm^2 . This implies that crack formed at the bottom of the structure was possibly due to the greater tensile stress developed at that level.

6. Conclusion

A cantilever type wall panel is susceptible to a structural failure from the foundation at a blast vibration level of 30.2 mm/s of ppv at a frequency of 50 Hz. FEM modeling that was done using SAP 2000 supports to this due to the increased stress concentration of the plaster which was greater than the splitting tensile stress of it.

References

- [1] The Nation, News Features, Sunday March 1st, 2009
- [2] Environmental Impact Monitoring Report-January to June 2010, Project Number: 26522, Southern Transport Development Project, Sri Lanka, August 2010
- [3] Interim Standards on Vibration Pollution Control, Central Environmental Authority, Sri Lanka
- [4] Sisikind D.E., Stagg M.S., Kopp J.W., Dowding C.H. ‘*Structure response and damage produced by ground vibration from surface mine blasting. Report of investigation 8507*’. Bureau of Mines, United States Department of Interior
- [5] Blastmate iii operator manual
- [6] SAP 2000 user manual
- [7] Bobby Motwani, “*Are We Ready for . . . "El Centro"?*”,03/03/10
- [8] Anil K. Chopra, “*Dynamics of Structures*” Prentice Hall 3rd edition
- [9] Matlab user manual
- [10] H.Sooriyarachchi, M.I.M.R.Khan, M.M.M.Munas, A.L.M.Shahabdeen, M,Prabahara ‘*Influence of the opening on the vibration damage to masonry construction caused by construction activities*’, Engineer_Vol XXXX11, No 04, pp[86-94], 20009