

# **OPTIMIZED ALTERNATIVE STRUCTURAL FORMS FOR STANDARD HIGHWAY BRIDGE BEAMS WITH HIGHER STRENGTH CONCRETES**

K S M Silva,  
Department of Civil Engineering,  
University of Moratuwa.  
Email: mangala\_xp@yahoo.com  
M T R Jayasinghe,  
Department of Civil Engineering,  
University of Moratuwa.  
Email: thishan@uom.lk

## **Abstract**

With the latest developments of concrete technology, it is possible to rely on concretes of higher strengths for normal construction activities with confidence. One of the features of stronger concretes is the ability to withstand higher compressive stresses. This advantage has been fully utilized to propose alternative structural forms for bridge decks using the standard T-beams where the possibility of using lesser number of beams and the lesser quantity of in-situ cast concrete is investigated. It is shown that there is a possibility to form robust bridge decks with half the number of beams when composite beam slab bridge decks are formed instead of pseudo-slab type bridges for the same span range.

**Keywords:** Precast concrete bridges, high strength concrete

# 1. Introduction

Bridges form a vital item in the highway infrastructure. Sri Lanka being a tropical country has many waterways. Thus, the use of precast prestressed concrete standard beams is popular. The grade of concrete is generally 40 with allowable stress at service being  $0.4 \times f_{cu}$ . This gives an allowable compressive stress of  $16 \text{ N/mm}^2$  under service conditions. However, the recent advances in concrete technology has made it possible to manufacture concretes of higher grades with the use of high grade water reducing admixtures, super plasticizers and also with the addition of silica fume, blast furnace slag and fly ash (Lewis, 2001, Saini et al., 2001). The use of higher strength concretes with standard beam sections has been explored in this research where special attention is placed to create alternative structural forms that would allow the use of lesser number of beams with lesser use of insitu cast concrete as well, thus creating the possibility for a significant level of optimization. The standard beam selected is Inverted T and the spans are in the range of 15-18 m.

## 2. Inverted T-type beams

Precast concrete beams as shown in Figure 1 can be placed touching each other have been a popular method for the construction of highway bridges in Sri Lanka. The main advantage is the beams of relatively light weight that can be placed with a crane touching each other as indicated in Figure 2. Once placed, insitu cast concrete can be placed to form a pseudo slab which primarily behaves similar to a reinforced concrete slab. However, there is a strong possibility to use these beams with a different structural form where the inverted Tee beams are placed with a spacing and only the top slab is cast if such an arrangement can be feasible structurally, as shown in Figure 3.

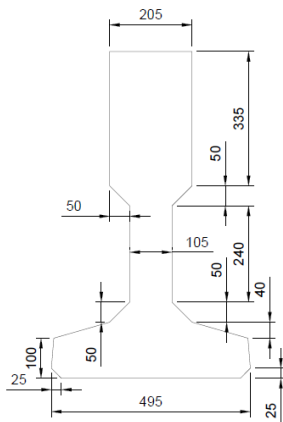

Figure 1- The Details of T10 Beam

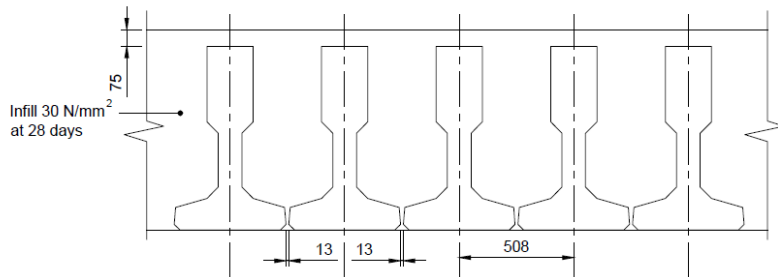
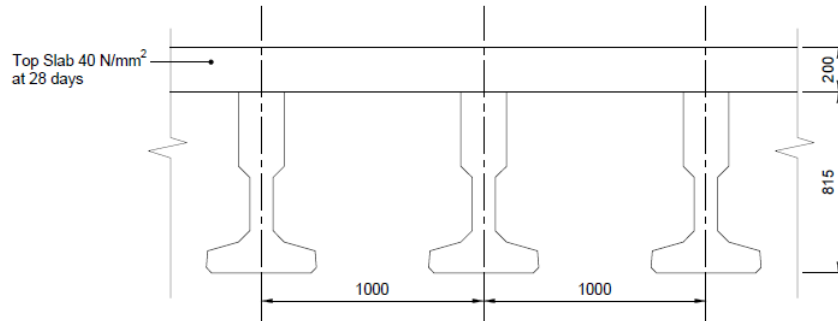

Figure 2- A typical cross section



**Figure 3- The proposed arrangement**

### **3. Higher strength concretes**

The use of concretes with higher strength is becoming practically possible with the introduction of high grade water reducing admixtures or super-plasticizers. In addition, it is possible to use silica fume and also fly ash to improve the durability. The use of concrete grades such as Grade 50 or 60 with large volumes is practically feasible (Lewis & Hasbi, 2001). It is shown by Sugathada and Jayasinghe (2004) that the aggregates available in Sri Lanka also can give such high strengths when silica fume is used with high end water reducing admixtures.

With grade 50 concrete, it is possible to have the allowable compressive stress under working conditions as  $20 \text{ N/mm}^2$  (BS 5400/4:1984). If the transfer is effected once the concrete reaches grade 40, the allowable compressive stress at transfer can also be as high as  $20 \text{ N/mm}^2$  (BS 5400/4:1984). Such larger stresses could allow an optimized usage of precast beams.

### **4. The advantages of alternative forms**

With the limited resources available, the cost of construction is increasing. Therefore, cost effective construction can be effected by optimizing the structural forms so that the quantities needed for completion can be reduced. In this context, the use of lesser number of beams and also reducing the quantities of in-situ cast concrete will be a distinct advantage.

### **5. The limitations due to stresses**

When prestressed concrete is used as a construction material, the stress range that can be allowed would be a governing condition. When inverted T type beams are used, one of the key parameters will be the tensile stress that can be allowed in the top fiber. According to BS 5400: Part 4: 1984, the allowable tensile stress is  $1 \text{ N/mm}^2$  at transfer. The use of a higher grade concrete will increase the allowable compressive stress up to  $20 \text{ N/mm}^2$ . This could allow a strategic selection of an eccentricity and a prestress force that would have advantages when the bridge is completed.

Once the beams are old enough, it is possible to place them with a gap and then a concrete top slab of 200 mm thickness can be cast. In this, the distance between centers of beams could vary from 750 mm to 1000 mm. If a distance of 1000 mm could be maintained, the number of beams needed to complete the bridge can be reduced by half. In addition, the use of a top slab only can further reduce the amount of in-situ cast concrete.

The penalty will be with the live loads. The distribution of live loads among the beams will be to a lesser extent due to the greater flexibility of the bridge deck. This will need a greater stress range in the bottom fiber of the precast beam. This can be achieved with the use of higher strength concrete for class 2 structures. On the one hand, the allowable tensile stress is higher. On the other, the higher allowable compressive stress can also increase the stress range. This means that the use of higher strength concretes can be the key for optimization.

When prestressed concrete inverted T beams are used for composite construction with a top slab as thick as 200 mm, the compressive stresses in the top fiber will not be a governing condition. However, it would be important to have adequate reinforcement projecting into the in-situ cast concrete to ensure the composite action where the interface shear can be resisted adequately with the reinforcement.

## **6. The loading and structural analysis**

The bridges constructed in Sri Lanka should be designed for 30 units of HB (RDA, 1997). For spans of 15-20 m range, the HB vehicle on the bridge can be a governing condition. The HB vehicle with 30 units will have a total weight of 120 tonnes with each axle carrying 30 tonnes (BS 5400: Part 2: 1978). These axles will be located at 1.8 m spacing. The minimum distance between the front and the rear axles will be 6.0 m. Therefore, one set of axles imposing 60 tonne load close to the center would be the governing load condition on the bridge. The HB would be governing for shear as well.

In order to obtain the influence of these HB loading, the bridge can be modeled using a grillage. The analysis has been carried out using a grillage created using SAP 2000 software. Since the beams are not strong in resisting torsion, a torsionless grillage has been used as allowed in BS 5400: Part 4:1984.

## **7. The results of design study**

For the design study, a T10 beam has been used. T-10 beam has a depth of 815 mm. The bottom flange is 495 mm of width. These beams can be located at 1000 mm centers. With a top slab of 200 mm, an overall depth of 1015 mm can be obtained. For a span such as 17 m, this can give a very robust bridge. The key feature would be the minimization of the number of beams and also minimizing the concrete quantity by having only a top flange consuming concrete. This will be a departure from beams located at 500 mm centers and also having a heavy infill in between the beams. The other advantage has been gained by using Grade 50 concrete that would allow a greater stress range than the typically used Grade 40 concrete.

The cross sectional area of T10 beam is about  $0.1715 \text{ m}^2$ . Hence, its self weight will be about  $4.1 \text{ kN/m}$ . This will give rise to a moment of about  $148 \text{ kNm}$  at the mid span. The weight of the top slab would be about  $4.8 \text{ kN/m}$ . It will give a moment of about  $173 \text{ kNm}$  at the mid span.

Once the top slab gains strength, the bridge will act as a composite beam slab bridge. Any load would have load sharing. This is valid for the pedestrian pavement, hand rails, asphalt paving, etc. The moment that can be expected due to these would be about  $60 \text{ kNm}$  at the mid span. The HB vehicle can give rise to a moment of about  $455 \text{ kNm}$ . It can be seen that the live load moment dominates in this bridge. The total moment due to permanent loads is about  $370 \text{ kNm}$ . The maximum live load with a partial factor of safety of 1.1 gives a moment of  $500 \text{ kNm}$ . HA loading along with pedestrian loads will also give a similar magnitude for a bridge of  $17 \text{ m}$  span.

For the above loading, the prestressed concrete beam of T10 type can be designed as follows:

1. Immediately after casting of the beam, the beam should be able to contain the maximum tensile stresses within a limit of  $1 \text{ N/mm}^2$  when the dead load is effective with a moment of about  $148 \text{ kNm}$  at the midspan. The stress at top fiber is  $0.9 \text{ N/mm}^2$ . The stress at bottom fiber is  $19.3 \text{ N/mm}^2$ . This clearly indicates that the higher strength concrete has been used to advantage with a greater stress range.
2. The beam should be able to resist the weight of the in-situ cast top slab without any supports with a moment of about  $173 \text{ kNm}$
3. The beam slab composite bridge would have to resist an additional superimposed dead load moment of about  $60 \text{ kNm}$
4. The beam slab composite bridge would have to resist an additional moment of about  $500 \text{ kNm}$  due to live loads

The relevant equations to be satisfied are given in Appendix A of this paper. The relevant section properties and the stresses under each critical stage have also be given. It can be seen that when a prestress of  $1800 \text{ kN}$  is applied with an eccentricity of  $253 \text{ mm}$ , it is possible to maintain the critical stresses within the limits. The prestress can be applied with the use  $15.2 \text{ mm}$  strands that can apply an initial prestress of about  $180 \text{ kN}$  per strand. The strand arrangement is 7 Nos at  $50 \text{ mm}$  from bottom fiber, 2 Nos at  $90 \text{ mm}$  from bottom fiber and one strand at  $500 \text{ mm}$  from the bottom fiber.

Under service conditions, the compressive stress at the top fiber is only  $9.6 \text{ N/mm}^2$ . This clearly indicates that compressive stress under live load conditions will not be critical. The stress in the bottom fiber in tension would be about  $1.1 \text{ N/mm}^2$ . The allowable is  $3.1 \text{ N/mm}^2$ . Thus, there is sufficient margin to take account of any stresses due to differential creep and shrinkage (Clark, 1983). Since the bearings will give a span shorter than the bridge, it would be possible to even use the same beams for a span of  $18 \text{ m}$  as well. Another advantage will be the lesser load on the foundations.

With the use of higher strength concretes for in-situ cast concrete as well, the ultimate capacity of the beam slab composite system can be enhanced. Thus, it is possible to ensure a robust bridge deck though it would primarily behave as a system that is unable to resist high torsional stresses and hence analyzed as

a torsionless system. The shear capacity of the reduced number of beams will not be a major problem since it can be carried by using the closely spaced high yield links.

It should be noted that T10 beam is recommended for a span range of 15m to 18 m when the beams are arranged touching each other. With half the number of beams and also with much less in-situ cast concrete, it would be possible to have a bridge deck that can give a similar performance when grade 50 concrete is used. This is a clear indication of the options that could be opened up with the use of higher strength concretes.

## **8. Conclusions**

With the escalation of construction costs that have been seen in the recent times, it is useful to optimize the usage of construction materials. In this context, the use of higher strength concretes can allow the use of standard inverted T-shaped sections with alternative cost effective structural forms. This paper has presented the possibility of using half the number of inverted T-beams to form a bridge deck with an alternative beam slab composite deck instead of a pseudo slab type that is used conventionally. The extra requirement will be the need for concretes of higher strength such as Grade 50. Such strengths can be achieved with the use of silica fume and fly-ash. Another advantage will be the higher capacity at ultimate limit state with the higher strength concretes. Thus, there is a possibility to create robust bridge decks with the use of stronger concretes with significant cost savings along with the saving in materials.

## **Acknowledgement**

This research is carried out at University of Moratuwa and any assistance received is acknowledged.

## **References**

BS 5400: Part 4: 1984, code of practice for the design of concrete bridges, BSI, London.

BS 5400: Part 2: 1978, Specification for load, BS steel, Concrete and composite bridges, BSI, London.

Clark, L.A (1983)., Concrete bridge design to BS 5400, Construction Press, England, 186p.

Lewis, R. C. (2001), "Ensuring long- term durability with high performance micro silica concrete", The Indian Concrete Journal, Vol 75, No 10, pp 621-626, Oct.

Lewis, R. C., Hasbi; S.A. (2001), "Use of silica fume concrete - Selective concrete studies", The Indian Concrete Journal, Vol 75, No 10, pp 645 – 655.

Road Development Authority (1997), Bridge Design Manual.

Saini, S., Dhuri, S.S., Kanhere, D. K., Momin, S. S. (2001), "High performance concrete for an urban viaduct in Mumbai", The Indian Concrete Journal, Vol 75, No 10, pp 634-644, Oct.

Sugathadasa, P.T.R.S., Jayasinghe, M.T.R. (2004), "The use of Silica fumes in Sri Lanka for improved strength and durability of concrete" *Engineer, Journal of Institution of Engineers, Sri Lanka*, Vol xxxvii, No: 2, pp 45-52.

Appendix A:

This presents the governing equations used and also the main details used for the design calculations.

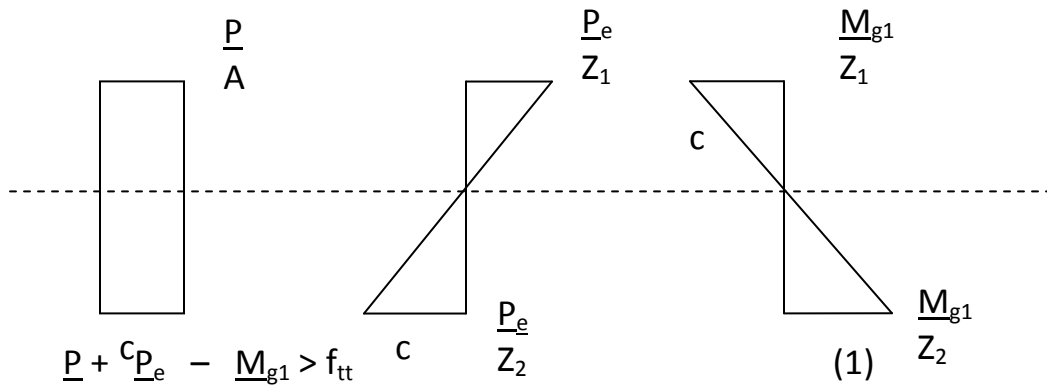

$$\frac{P}{A} + \frac{cP_e}{Z_1} - \frac{M_{g1}}{Z_1} > f_{tt}$$

$$(1) \quad \frac{P_e}{Z_2}$$

$$\frac{P}{A} + \frac{P_e}{Z_2} - \frac{M_{g1}}{Z_2} < f_{ct}$$

$$(2)$$

$$\frac{RP}{A} + \frac{RP_e}{Z_1} - \frac{M_{g1}}{Z_1} - \frac{M_{g2}}{Z'_1} - \frac{M_{q1}}{Z'_1} < f_{cw}$$

$$(3)$$

$$\frac{RP}{A} + \frac{RP_e}{Z_2} - \frac{M_{g1}}{Z_2} - \frac{M_{g2}}{Z'_2} - \frac{M_{q1}}{Z'_2} > f_{tw}$$

$$(4)$$

$Z_1$  = Section modulus for top fiber (-) ve.

$Z_2$  = Section modulus for bottom fiber (+) ve.

$Z'_1$  = Section modulus for top fiber with composite (-) ve.

$Z'_2$  = Section modulus for bottom fiber with composite (+) ve.